

Model B-1 Foam-Water Sprinklers

Features

- Pendent or upright installation
- Foam discharge in spray pattern
- Open-head design
- Quickly blankets the area with foam
- UL Listed

Description

The Model B-1 Upright and Pendent Foam-Water Sprinklers manufactured by Tyco Fire Protection Products are air-aspirating foam discharge outlets designed for use in foam-water deluge systems. They are designed for flammable liquid risks where it is desired to apply foam from overhead sprinklers (either upright or pendent) and where follow-up with plain water in a standard spray sprinkler pattern is necessary. See NFPA 16, "Standard for the Installation of Foam-Water Sprinkler and Foam-Water Spray Systems," for more information.

The Model B-1 Sprinklers were also formerly available as Gem Issue B-1 and Star Model B-1.

Approvals

The Model B-1 Sprinklers are UL Listed. Discharge outlets and foam concentrates are listed for use together. Refer to the individual foam concentrate listing for operating limitations and compatibility with the B-1 Foam-Water Sprinklers as provided in the UL Online Certifications Directory.

The Model B-1 Sprinklers meet the requirements of MIL-S-901C for lightweight Grade A shockproof equipment, as well as the requirements of MIL-H-24146.



001600

Specifications

Working pressure:	30 psi to 175 psi (2.1 bar to 12.1 bar)
Discharge coefficient:	K = 3.0
Finishes:	Natural Bronze
Physical characteristics:	Body – Bronze, Deflector – Brass, Agitator – Brass
Pipe thread connection:	1/2 in. NPT
Nominal orifice size:	3/8 in. (9.5 mm) at throat

Operation

The Model B-1 Foam-Water Sprinklers are designed with a unique venturi-style body. As foam solution (water and foam concentrate mixture) flows through the inlet of the body, air is drawn into the body through the openings adjacent to the wrenching area. The foam solution and air mix is then agitated to create an air-aspirated foam.

The Model B-1 Foam-Water Sprinklers are designed to discharge foam in a pre-determined discharge pattern, as well as to discharge water similar to standard spray sprinklers. To meet the intent of NFPA 16, foam-water sprinklers must be able to sufficiently distribute water after depletion of the foam concentrate.

Design

The Model B-1 Upright and Pendent Foam-Water Sprinklers are intended for fire protection systems designed in accordance with the standard installation rules for foam-water sprinklers systems recognized by the applicable Listing Agency (e.g., UL Listing is based on the requirements of NFPA 13 and 16).

Not less than two foam-water sprinklers are to be installed in any area, regardless of size, in order to obtain pattern overlap.

The applied density (flow per unit of area) of foam solution must meet the requirements of the Authority Having Jurisdiction for the type of flammable liquid and occupancy. Per NFPA 16, coverage density must not be less than 0.16 gpm/ft² (6.52 Lpm/m²) of floor area with a resulting minimum discharge pressure of no less than 30 psi (2.1 bar).

Foam-water sprinkler spacing must not exceed the requirements of NFPA 13 for extra hazard occupancies, and the system must use hydraulic calculations to obtain the required density and discharge pressure.

Note: Discharge outlets and foam concentrates are listed for use together. Refer to the individual foam concentrate listing for operating limitations and compatibility with the B-1 Foam-Water Sprinklers as provided in the UL Online Certifications Directory.

Ordering Information

Part No.	Description
422711	Upright B-1 Foam-Water Sprinkler
72535	Pendent B-1 Foam-Water Sprinkler

Note: The converted metric values in this document are provided for dimensional reference only and do not reflect an actual measurement.

CHEMGUARD and the product names listed in this material are marks and/or registered marks. Unauthorized use is strictly prohibited.

Model B-1 Upright and Pendent Foam-Water Sprinklers Nominal Dimensions

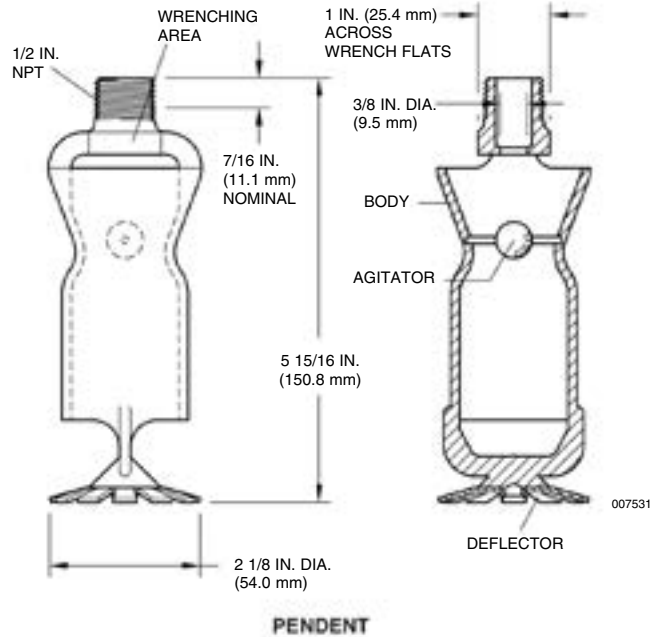
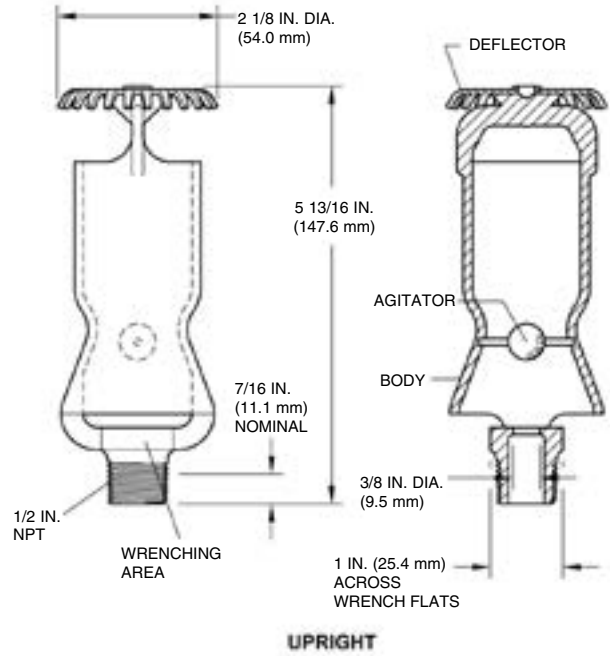

007531