

Touch panel (EUI)

Achieving Efficient and Accurate Labeling for Empty Bags

This machine is a desktop empty bag labeling machine with conveyor for applying labels onto empty bags before product filling.

By this automatic label applying system, it contributes to labor saving, productivity improvement and quality improvement.

Productivity

The labeling work by mechanization from manpower, contributing to the improvement of productivity.

Variety Registration

Such as label applying position, setting each type of product can be registered.

Touch Panel

Simple selection by the touch panel at the time of product changing.

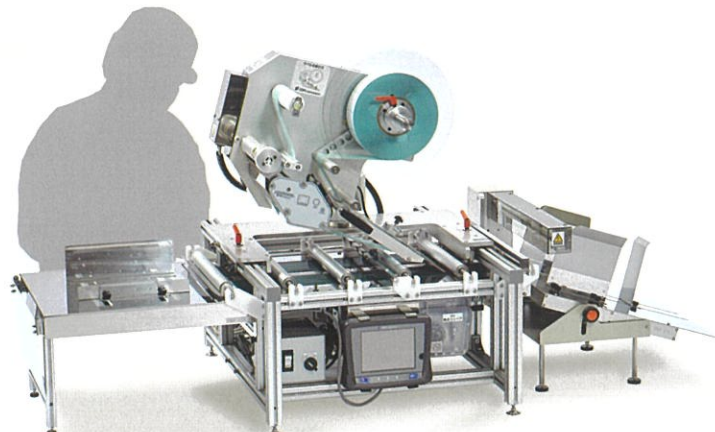

Outline Dimensional Drawing (LMFe6000NS12-FJ with option)

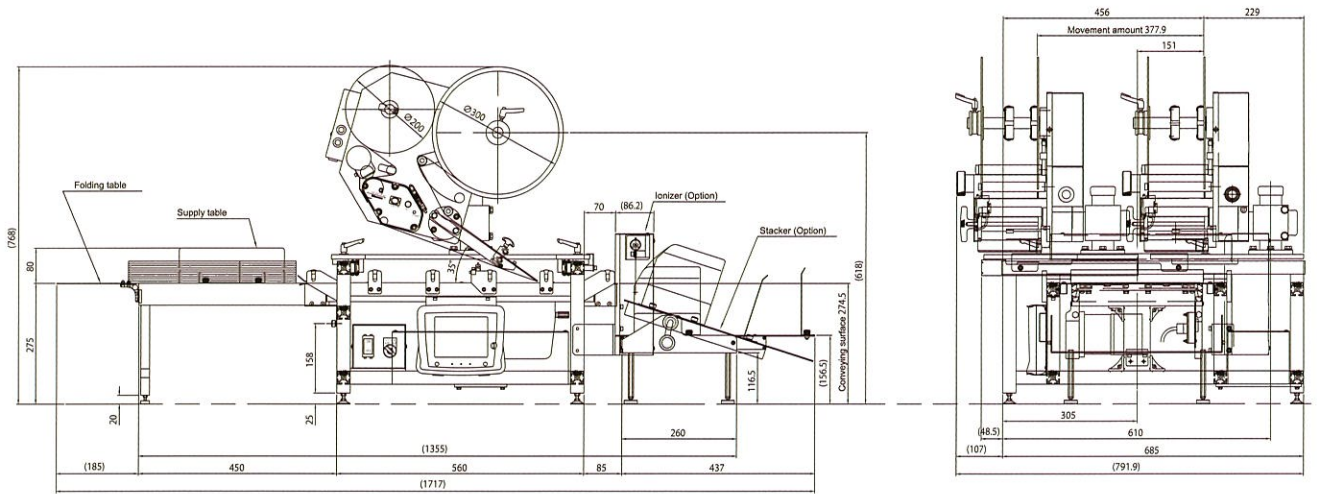

(Unit: mm)

Automatic feeder connection available.
The work efficiency of off-line labeling can be dramatically improved.

Preset counter

Bag loading number
500 sheets

Maximum capacity
45 pieces / min*

* 200 mm bag length
16.8m / min speed condition

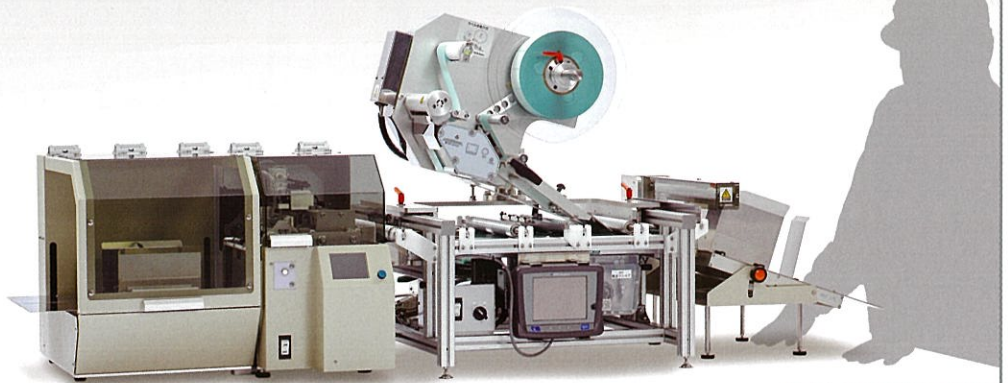

LMFe6000NS12-FJV

SPECIFICATION

Model	LMFe6000FJ	Conveyor Spec.	Belt Width: 232mm
Variety Registration	200		Belt Length: 700mm
Supported bag size	Bag Width: 70mm-285mm		Transfer Speed: 2M/min - 24.5M/min *
	Bag Length: 130mm-380mm		(* Fixed speed at the operation)
Label Spec.	Label Width: 15mm-120mm	Power Supply	AC100V, 600VA
	Basement Paper Width: 18mm-125mm	Operating Environment	Temperature : 5°C-40°C
	Label Length: 15mm-200mm		Humidity : Under 90%RH (no dew condensation)
	Roll Diameter : (O.D) ϕ 300mm	Option	Automatic
	Paper Core : (I.D) ϕ 75mm		

The specification may differ from conditions of use. Specification and other information notice.

EDM CORPORATION

5-2,3-Chome Itabashi, Itabashi-ku, Tokyo, Japan
 TEL : +81-3-3964-4852 FAX : +81-3-3962-1277
 URL : <http://www.edm-net.co.jp/>

Agency

ต้นฉบับควบคุม
 วันที่เริ่มใช้ 1 8 66
 ผู้จัดทำ อิศรา ทิม
 20 7 66
 ผู้อนุมัติใช้
 20 7 66